

# 56 SERIES

## Single Stack Filter Housing



The **56 Series** single cartridge housing is renowned for its high quality design and manufacture and accepts both standard Double Open End and Single Open End cartridges. The housing has a high security bolted closure and is particularly suitable for hazardous liquid and gas applications.

The **56 Series** will accept the full range of Amazon and industry standard cartridges ranging from 0.1 to 500µm with nominal lengths of 5, 10, 20 and 30".



### Product Features

- High security bolted closure suitable for hazardous applications
- Dual purpose head accepts SOE code 3 and DOE cartridges
- SOE code 7 and code B adaptors available
- Offered with a wide range of connection sizes and types
- Available for a range of cartridge lengths
- PED and ATEX Compliant
- Full traceability on all parts, material certification packs available
- Rated at 10 bar g and full vacuum in liquids
- Rated at 9 bar g and full vacuum in gases
- Available in 316L stainless steel or Alloy 22 for maximum compatibility

## Features and Benefits

- Bolted closure provides high security housing sealing
- Suitable for hazardous liquid and gas applications
- Full vacuum rating in liquids and gases
- Integral vent and drain sockets to aid efficient filter change-out complete with PTFE washer
- Unique interchangeable configuration enables choice of SOE or DOE cartridge styles in the same housing
- Every housing is etched with a serial number for full traceability
- Full housing customisation service available

## Product Range

Amazon Filters design and manufacture an extensive range of liquid filtration systems, providing one of the widest selections of filtration vessels, depth filters and pleated cartridges available today, ensuring excellent process and filter compatibility. As one of Europe's leading manufacturers of filtration systems, Amazon Filters is able to offer a solution to meet all filtration requirements. Amazons' filters are manufactured in clean room conditions and all products come with detailed Product Validation Guides and Technical Support documentation.



**AMAZON**

# 56 Series Technical Data

## Maximum Operating Conditions

Pressure Range: Liquid: FV / 10 bar g  
 Gas: 10" & 20": FV / 10 bar g  
 30": FV / 9 bar g

Temperature Range: -10°C / 150°C

## Materials of Construction

Body and Closure: 316L St. Steel  
 Alloy 22  
 Seal: Ethylene Propylene

## Finish

Vessel: Externally polished sump, electropolished head

## Connections

Inlet/Outlet: 1" BSPF  
 Vent: ¼" BSPF with Plug  
 Drain: ¼" BSPF with Plug

Model	Dimensions					Volume (Litres)	Dry Weight
	A	B	C	D	E		
10"	343	-	-	120	300	2.2	7.2
20"	597	-	-	120	554	3.8	8.2
30"	851	-	-	120	808	5.2	9.2

## PED Status:

Compliant with 97/23/EC

Fluid Groups:

Gas Group 1 + 2  
 Liquids Group 1 + 2

Marking:

CE Marked

Exceptions:

Group 1 liquids - Explosive

## ATEX:

Compliant 94/9/EC, level CE Ex II 2 GD c X

Technical drawings for each individual housing showing dimensions, volume, weights, maximum temperatures and design pressures available on request.

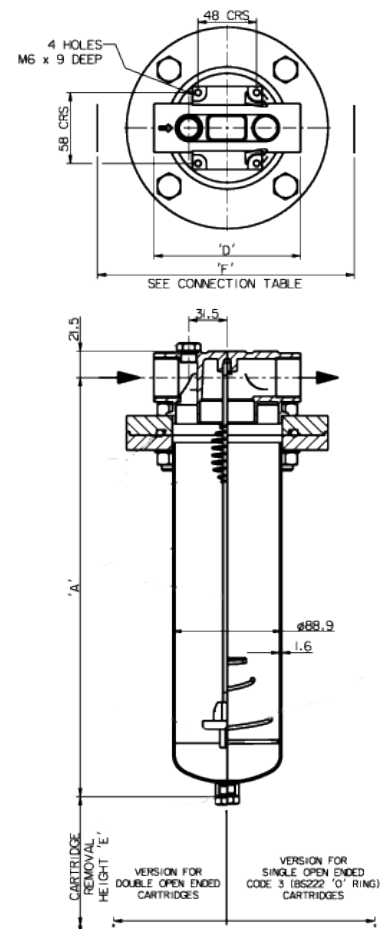

# AMAZON FILTERS LTD.

ALBANY PARK ESTATE, FRIMLEY ROAD  
 CAMBERLEY, SURREY, GU16 7PG  
 ENGLAND

**Tel.** +44 (0) 1276 670600  
**Fax.** +44 (0) 1276 670101  
**Email.** sales@amazonfilters.co.uk  
**Web.** www.amazonfilters.com